

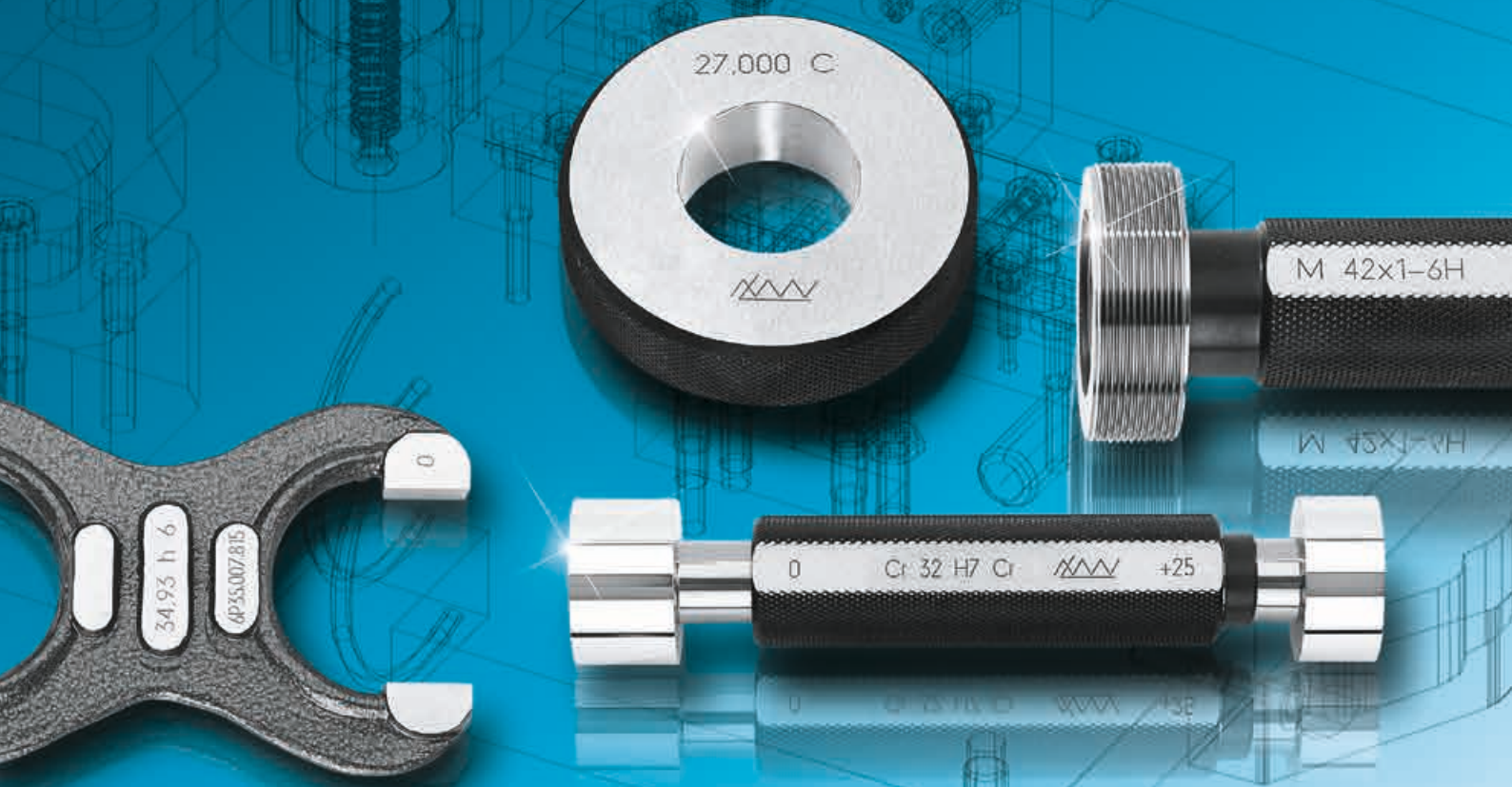

Lehren- und Meßgerätewerk Schmalkalden



Precision Gauges
and Measuring Instruments

Contents



General on thread gauges	4
Tolerances	5
Thread gauges available versions	6
• Metric ISO threads – available versions	6
• Metric ISO threads – coarse and fine threads	10
• Unified threads	11
• British-Standard Whitworth threads	12
• Metric ISO trapezoidal threads	12
• Pipe threads	12,13
• Edison threads	13
Special threads	13
Sets of gauges	17
Protection boxes	17



Manufacturing tolerances and allowed wear	20
Limit plug gauges	21
Flat limit plug gauges	23
Square and hexagon limit plug gauges	24
Limit snap gauges	25
Limit snap gauges for groove diameters and groove width	27
Setting ring gauges	28
Keyseating gauges for shafts	29
Keyseating gauges for hubs	30
Limit keyseating gauges	31
Precision cylindrical squares	32
Taper gauges	33
Testing plug gauges	35
Cylindrical checking pins	36
Gauges for spline profiles	37



Gauges for medical appliances	40
Gauges according to customer specifications	41



Calibration service	44
----------------------------	-----------

Explanation of symbols

Available special designs



Intermediate measures



Dirt or air groove



Piloting collar groove



Inspection gauges



Elongated gauging surface



Handles in special length



Handles with 2nd marking field

Imprint

Lehren- und Meßgerätewerk Schmalkalden GmbH

Wilhelm-Külz-Strasse 49
98574 Schmalkalden
Germany

Telefon +49-(0)3683-668-0
Telefax +49-(0)3683/668-100

www.lehrmess.de
info@lehrmess.de

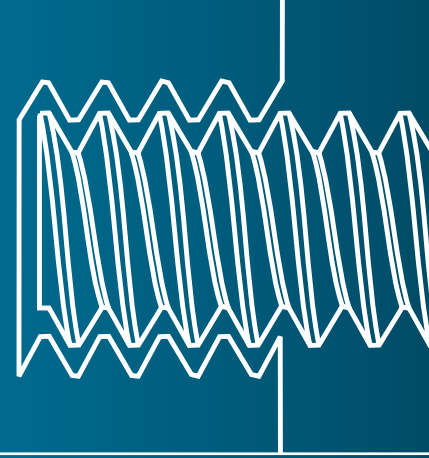

0

Thread gauges

Thread inspection

The inspection of interchangeability and threads is ensured by use of thread limit gauges. External and internal threads correspond to the standard if they are found to be within tolerance when inspected with appropriate thread limit gauges.

As far as mating ability is concerned, a thread depends on 5 parameters:

- major diameter
- pitch diameter
- minor diameter
- pitch respectively lead
- flank angle

Since pitch diameter, flank angle and lead depend geometrically on each other, deviations of the pitch respectively lead and of the flank angle always become perceptible at the mating of external and internal threads in the pitch diameter (virtual pitch diameter). According to the Taylor principle, GO-gauges are carried out always with the full profile of thread (form-ideal counterpiece). The length of the thread of GO-gauges should amount at least 80 % of the length of thread engagement.

For the efficient inspection of threads in the practice are required:

- 1. For the internal thread:**
Limit thread plug gauges
- 2. For the external thread:**
Go and No Go thread ring gauges
Limit thread caliper gauges
- 3. For the setting of limit thread caliper gauges:**
Limit thread setting gauges.
- 4. For the inspection of new thread ring gauges:**
Go and No Go check plugs
- 5. For wear inspection of thread ring gauges:**
Wear check plug gauges
- 6. For the inspection of the minor diameter of internal threads:**
Plain limit plug gauges
- 7. For the inspection of the major diameter of external threads:**
Plain limit gap gauges
Plain Go and No Go ring gauges

The ISO-system for thread tolerances provides several tolerance classes of the major diameter, of the pitch diameter and of the minor diameter (DIN ISO 965-1).

The following table shows for the length group of thread engagement N the standardized tolerance classes for the tolerance qualities fine, medium and coarse. The marked fields should be preferred.

If the tolerance classes for the pitch diameter and the major diameter of the external thread or the pitch diameter and the minor diameter of the internal thread are equal, it is not necessary to repeat the specification of the tolerance class.

		Length group of thread engagement N			
Tolerance quality	Tolerance classes for external thread				
	fine	-	-	4e	4g
medium	-	-	6e	6g	6h
coarse	-	-	8e	8g	-
		Tolerance classes for internal thread			
fine	5G	5H			
medium	6G	6H			
coarse	7G	7H			

Sample M12 - 6H:

Same tolerance classes for the pitch and the minor diameter.

Sample M12 - 4H6H:

- 4H** tolerance class for the pitch diameter
6H tolerance class for the minor diameter

For threads without corresponding information, always length group of thread engagement N applies.

Thread gauges for ISO-metric screw thread according to DIN 13, DIN ISO 68-1, DIN ISO 965

Types:

- Limit thread plug gauge
DIN 2280
- Go thread plug gauge
DIN 2281 · Part 1 and Part 2
- No Go thread plug gauge
DIN 2283 · Part 1 and Part 2
- Go thread ring gauge
DIN 2285 · Part 1
- No Go thread ring gauge
DIN 2299 Part 1
- Limit thread caliper gauge
- Limit thread setting gauge
- Wear check plug gauges for Go and No Go thread ring gauges

Gauges for left-hand thread and sizes not included in the following overviews or gauges with tolerance classes not standardized according to DIN ISO 965 are also manufactured on request.



ISO-metric screw thread DIN 13, DIN ISO 68-1, DIN ISO 965

Tolerance classes for length group of thread engagement **N** (normal)

Gauge dimensions DIN ISO 1502

Tolerance quality	Tolerance class external thread	Tolerance class internal thread	Surface condition
fine (f)	4 h	5 H	blank or thin phosphate coating
medium (m)	for threads 1 - 1,4 mm 6 h	for threads 1 - 1,4 mm 5 H	blank, phosphate coating or thin galvanic protection layer
	for threads above 1,4 mm 6 g	for threads above 1,4 mm 6 H	
coarse (g)	8 g	7 H	

British Standard Whitworth threads · Standard- and fine threads BS 84

Gauge dimensions BS 919

External thread	close class	medium class*	free class*
Internal thread	medium class	normal class	normal class

* GO thread ring gauges, NO GO thread ring gauges and limit thread caliper gauges as well as limit thread setting gauges for external threads up to 3/4" nominal size are supplied in the tolerance classes "medium" and "free" in the outfit "unplated".

If the outfit "afterplating" is required this has to be indicated separately when ordering.

Cylindrical pipe threads DIN EN ISO 228-1

Gauge dimensions DIN EN ISO 228-2

Tolerance class	external thread	A	B
Tolerance class	internal thread	(only one tolerance class)	

ISO-metric trapezoidal threads DIN 103

Tolerance classes for length group of thread engagement **N** (normal)

Gauge dimensions DIN 103 part 9

Tolerance quality	Tolerance class external thread	Tolerance class internal thread
medium (m)	7 e	7 H
coarse (g)	8 c	8 H

Round thread DIN 405

Tolerance classes for length group of thread engagement **N** (normal)

Gauge dimensions DIN 405-3

Tolerance class external thread		Tolerance class internal thread
7 h	7 e	7 H

Unified threads ASME B1.1

UNC, UNF, UNEF, 4-UN, 6-UN, 8-UN, 12-UN, 16-UN, 20-UN, 28-UN, 32-UN, UNS

Gauge dimensions for thread plug gauges: ASME B1.2, thread ring gauges: BS 919.

In case of customer request, it is possible to deliver solid thread ring gauges for Unified threads according to ANSI B1.2.

In this case the solid thread ring gauges are manufactured with the tolerances for adjustable thread ring gauges.

Tolerance class			
External thread	1 A	2 A	3 A
Internal thread	1 B	2 B	3 B

If the order doesn't contain a tolerance class, we deliver the blue marked tolerance class of the tables.

NoGo thread plug gauges or no go parts of limit thread plug gauges according to ANSI B1.2 for Unified threads are delivered with "minus" tolerance. If a "plus" tolerance is required, it has to be indicated in the order.

Thread gauges for metric ISO threads - available versions



▲ Limit thread plug gauge
available nominal sizes 1 mm – 40 mm

Limit thread plug gauge

available nominal sizes
1 - 40 mm

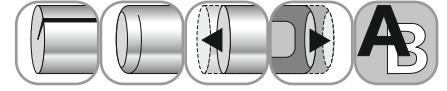

▲ Go thread plug gauge
available nominal sizes 1 – 300 mm

Go thread plug gauge

available nominal sizes
1 - 300 mm

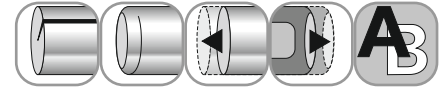

▲ No Go thread plug gauge
available nominal sizes 1 – 300 mm

No Go thread plug gauge

available nominal sizes
1 - 300 mm

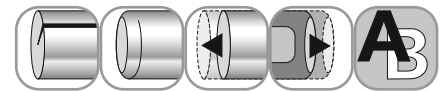

▲ Go thread ring gauge

No Go thread ring gauge

available nominal sizes
1 - 300 mm



No Go thread ring gauge ▶



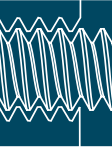

Thread limit setting gauge

available nominal sizes

1 - 40 mm

Over 40 mm delivered as thread
Go setting gauge and thread No Go
setting gauge



▲ Thread limit setting gauge

Thread limit caliper gauge

available nominal sizes

3 - 200 mm



◀ Thread limit caliper gauge

Limit plug gauge for minor diameter

available nominal sizes

1 - 300 mm

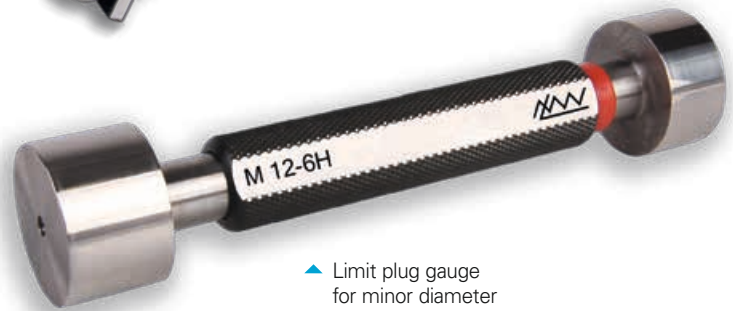

▲ Limit plug gauge
for minor diameter

Go check plug gauge for Go thread ring gauge

available nominal sizes

1 - 300 mm

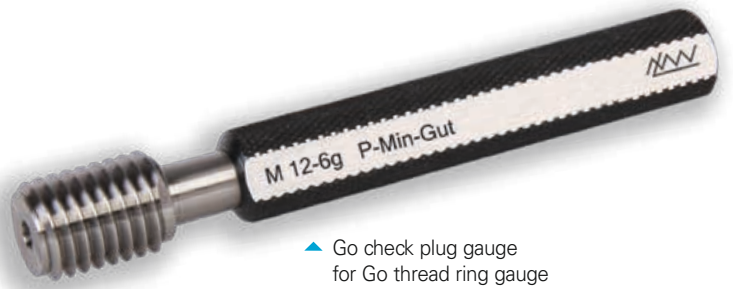

▲ Go check plug gauge
for Go thread ring gauge

No Go check plug gauge for Go thread ring gauge

available nominal sizes

1 - 300 mm



▼ No Go check plug gauge
for Go thread ring gauge

Thread gauges for metric ISO threads - available versions

0

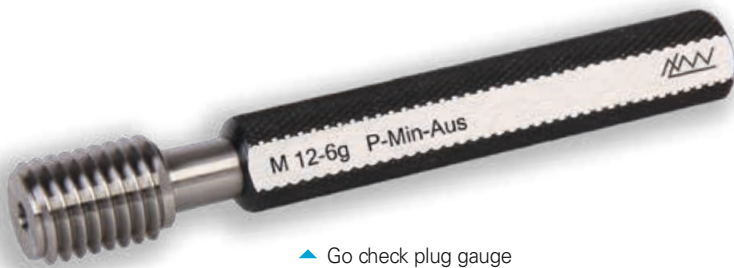

▲ Go check plug gauge for No Go thread ring gauge

Go check plug gauge for No Go thread ring gauge
available nominal sizes
1 - 300 mm

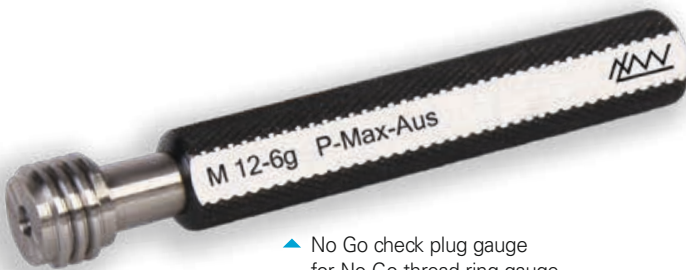

▲ No Go check plug gauge for No Go thread ring gauge

No Go check plug gauge for No Go thread ring gauge
available nominal sizes
1 - 300 mm

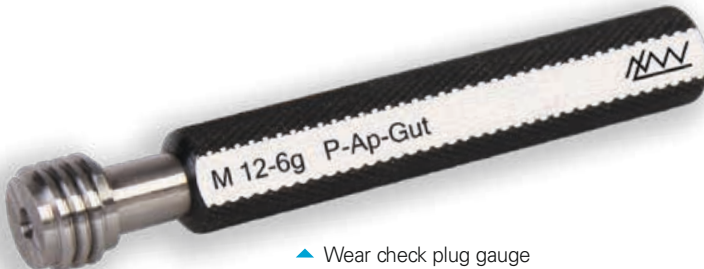

▲ Wear check plug gauge for Go thread ring gauge

Wear check plug gauge for Go thread ring gauge
available nominal sizes
1 - 300 mm



▲ Wear check plug gauge for No Go thread ring gauge

Wear check plug gauge for No Go thread ring gauge
available nominal sizes
1 - 300 mm



Thread gauges for metric ISO threads - available versions

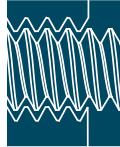

0

Go and No Go ring gauge for major diameter

available nominal sizes
1 - 300 mm

Go ring gauge ▶
for major diameter



Snap gauge for major diameter

available nominal sizes
1 - 300 mm



◀ Snap gauge
for major diameter

Thread setting plug gauge

acc. to DIN 2241



▶ Thread setting
plug gauge

Thread setting ring gauge

acc. to DIN 2241



◀ Thread setting
ring gauge

Thread gauges for metric ISO threads - coarse pitch thread and fine thread

0



Limit thread plug gauge

available nominal sizes: 1-40 mm

Versions and pitch Metric ISO threads	No.
Coarse thread	0000
Fine thread, P=0,2	0010
Fine thread, P=0,25	0020
Fine thread, P=0,35	0030
Fine thread, P=0,5	0040
Fine thread, P=0,75	0050
Fine thread, P=1,0	0060
Fine thread, P=1,25	0070
Fine thread, P=1,5	0080
Fine thread, P=2,0	0090
Fine thread, P=3,0	00A0
Fine thread, P=4,0	00B0
Fine thread, P=6,0	00C0

unlisted diameter-pitch combinations:
request for quotation required



Go thread plug gauge

available nominal sizes: 1-300 mm

Versions and pitch Metric ISO threads	No.
Coarse thread	0001
Fine thread, P=0,2	0011
Fine thread, P=0,25	0021
Fine thread, P=0,35	0031
Fine thread, P=0,5	0041
Fine thread, P=0,75	0051
Fine thread, P=1,0	0061
Fine thread, P=1,25	0071
Fine thread, P=1,5	0081
Fine thread, P=2,0	0091
Fine thread, P=3,0	00A1
Fine thread, P=4,0	00B1
Fine thread, P=6,0	00C1

unlisted diameter-pitch combinations:
request for quotation required



No Go thread plug gauge

available nominal sizes: 1-300 mm

Versions and pitch Metric ISO threads	No.
Coarse thread	0002
Fine thread, P=0,2	0012
Fine thread, P=0,25	0022
Fine thread, P=0,35	0032
Fine thread, P=0,5	0042
Fine thread, P=0,75	0052
Fine thread, P=1,0	0062
Fine thread, P=1,25	0072
Fine thread, P=1,5	0082
Fine thread, P=2,0	0092
Fine thread, P=3,0	00A2
Fine thread, P=4,0	00B2
Fine thread, P=6,0	00C2

unlisted diameter-pitch combinations:
request for quotation required



Go thread ring gauge

available nominal sizes: 1-300 mm

Versions and pitch Metric ISO threads	No.
Coarse thread	0003
Fine thread, P=0,2	0013
Fine thread, P=0,25	0023
Fine thread, P=0,35	0033
Fine thread, P=0,5	0043
Fine thread, P=0,75	0053
Fine thread, P=1,0	0063
Fine thread, P=1,25	0073
Fine thread, P=1,5	0083
Fine thread, P=2,0	0093
Fine thread, P=3,0	00A3
Fine thread, P=4,0	00B3
Fine thread, P=6,0	00C3

unlisted diameter-pitch combinations:
request for quotation required



No Go thread ring gauge

available nominal sizes: 1-300 mm

Versions and pitch Metric ISO threads	No.
Coarse thread	0004
Fine thread, P=0,2	0014
Fine thread, P=0,25	0024
Fine thread, P=0,35	0034
Fine thread, P=0,5	0044
Fine thread, P=0,75	0054
Fine thread, P=1,0	0064
Fine thread, P=1,25	0074
Fine thread, P=1,5	0084
Fine thread, P=2,0	0094
Fine thread, P=3,0	00A4
Fine thread, P=4,0	00B4
Fine thread, P=6,0	00C4

unlisted diameter-pitch combinations:
request for quotation required



Limit thread setting gauge or Go setting gauge and No go setting gauge

available nominal sizes

Limit thread setting gauge: 1 – 40 mm

Go or No Go setting gauge: 40 – 300 mm

Versions and pitch Metric ISO threads	No.
Coarse thread	0005
Fine thread, P=0,2	0015
Fine thread, P=0,25	0025
Fine thread, P=0,35	0035
Fine thread, P=0,5	0045
Fine thread, P=0,75	0055
Fine thread, P=1,0	0065
Fine thread, P=1,25	0075
Fine thread, P=1,5	0085
Fine thread, P=2,0	0095
Fine thread, P=3,0	00A5
Fine thread, P=4,0	00B5
Fine thread, P=6,0	00C5

unlisted diameter-pitch combinations:
request for quotation required

Thread gauges for Unified threads



Coarse UNC series

acc. ASME B 1.1

Sizes in the standard range Nr. 1 - 64 - 4 - 4	No.
Limit thread plug gauge	0300
Go thread plug gauge	0301
No Go thread plug gauge	0302
Go thread ring gauge	0303
No Go thread ring gauge	0304
Limit thread setting gauge	0305

Fine UNF series

acc. ASME B 1.1

Sizes in the standard range Nr. 0 - 80 - 1 1/2 - 12	No.
Limit thread plug gauge	0310
Go thread plug gauge	0311
No Go thread plug gauge	0312
Go thread ring gauge	0313
No Go thread ring gauge	0314
Limit thread setting gauge	0315

Series Extra Fine UNEF

acc. ASME B 1.1

Sizes in the standard range Nr. 12 - 32 - 1 11/16 - 18	No.
Limit thread plug gauge	0320
Go thread plug gauge	0321
No Go thread plug gauge	0322
Go thread ring gauge	0323
No Go thread ring gauge	0324
Limit thread setting gauge	0325

UN and UNS threads with specification of the diameter-pitch combination per request.

Remark

Ordering thread ring gauges for unified thread according to USA gauge standard

Solid thread ring gauges for Unified screw threads are not defined in the USA gauge standard ANSI B1.2. In this standard are specified dimensions and tolerances for adjustable thread ring gauges.

Gauge dimensions and tolerance for solid thread ring gauges for Unified thread accord ASME B 1.1 are defined in the british standard BS 919. For this reason, unless differently specified, we manufacture the solid thread ring gauges for Unified thread according to BS 919.

Following specific customer's requirement is the delivery of solid thread ring gauges for Unified thread also possible according to ANSI B1.2 . The solid thread ring gauges will be manufactured, in this specific case, according to the tolerances for adjustable thread ring gauges.

Thread gauges for British Standard threads of whitworth

ISO-metric trapezoidal screw threads



Go thread ring gauge for British Standard threads of whitworth

Limit thread plug gauge for British Standard threads of whitworth



Limit thread plug gauge and No go thread ring gauge for ISO-metric trapezoidal screw threads



Trapezoidal screw threads

acc. DIN 103
recommended tolerance fields for pitch diameters

Tolerance quality	length group of thread engagement N	
	Internal thread	External thread
medium	7 H	7 e
coarse	8 H	8 c

Standard Whitworth BSW

acc. BS 84

Sizes in the standard range $1/8 - 40 - 6 - 2 1/2$	No.	Sizes in the standard range $3/16 - 32 - 6 - 2 1/2$	No.
Limit thread plug gauge	0500	Limit thread plug gauge	0510
Go thread plug gauge	0501	Go thread plug gauge	0511
No Go thread plug gauge	0502	No Go thread plug gauge	0512
Go thread ring gauge	0503	Go thread ring gauge	0513
No Go thread ring gauge	0504	No Go thread ring gauge	0514
Limit thread setting gauge	0505	Limit thread setting gauge	0515

Whitworth threads acc. BS84/BS 919 with specification of diameter-pitch combinations: request for quotation required.

Fine thread BSF

acc. BS 84

Sizes in the standard range Tr 8 x 1,5 - Tr 60 x 9	No.
Limit thread plug gauge	0100
Go thread plug gauge	0101
No Go thread plug gauge	0102
Go thread ring gauge	0103
No Go thread ring gauge	0104
Limit thread setting gauge	0105

Not standardized sizes and diameter-pitch combinations: request for quotation required.

Thread gauges for pipe threads

Cylindrical pipe thread for not-self-sealing thread connections

acc. to DIN EN ISO 228-1

Designations e.g. for nominal size $1 1/2$

Internal thread	External thread	
	Tolerance class A	Tolerance class B
G $1 1/2$	G $1 1/2$ A	G $1 1/2$ B

Sizes in standard range G $1/16 - G 6$	No.	Sizes in standard range Pg 7 - Pg 48	No.	Sizes in standard range $1/16 - 6$	No.
Limit thread plug gauge	0400	Limit thread plug gauge (plain No Go side)	0600	Limit thread plug gauge, conical	0700
Go thread plug gauge	0401				
No Go thread plug gauge	0402				
Go thread ring gauge	0403	Go thread ring gauge	0603	Limit thread ring gauge, cylindrical	0707
No Go thread ring gauge	0404	No Go ring gauge, plain	0604		
Limit thread setting gauge	0405				

*Attention! DIN 2999 was replaced DIN EN 10226; new system accord DIN EN 10226-3 / ISO 7-2 make inquiry



Steel conduit threads

acc. DIN 40430



Pipe thread for in the thread sealing connections

acc. DIN 2999 (July 1983)*





Pipe thread general purpose NPT

acc. ASME B 1.20.1

Dryseal pipe threads NPTF

acc. ASME B 1.20.3

Edison threads

acc. DIN 40400

Sizes in the standard range 1/16 - 27 NPT - 8 - 8 NPT	No.	Sizes in the standard range 1/16 - 27 NPTF - 3 - 8 NPTF	No.	Sizes in the standard range E 14 - E 33	No.
Limit thread plug gauge	0710	Limit thread plug gauge	0720	Limit thread plug gauge mit (plain No Go side)	0670
Limit thread ring gauge	0717	Limit thread ring gauge	0727	Go thread ring gauge	0673
Execution two- stepped (Go and No Go); standard gauge type (without Go and No Go stepped) request for quotation required		Execution two- stepped (Go and No Go) accord ASA B2.2; Gauge system accord ASME B1.20.5: request for quotation required		No Go ring gauge, plain	0674

Limit plug gauge with special characteristics

We are available to provide Limit plug gauges with special specifications.

This includes the determination of the tolerance, the choice of material, a possible coating and the execution of dimensions for special purposes.

The relevant document for Limit plug gauges and Limit thread plug gauges are on our website at MEDIA under Technology.

Or under the link:

Limit thread plug gauge

<https://www.lehrmess.de/images/media/Formular-Gewinde-Grenzlehrdorn.pdf>

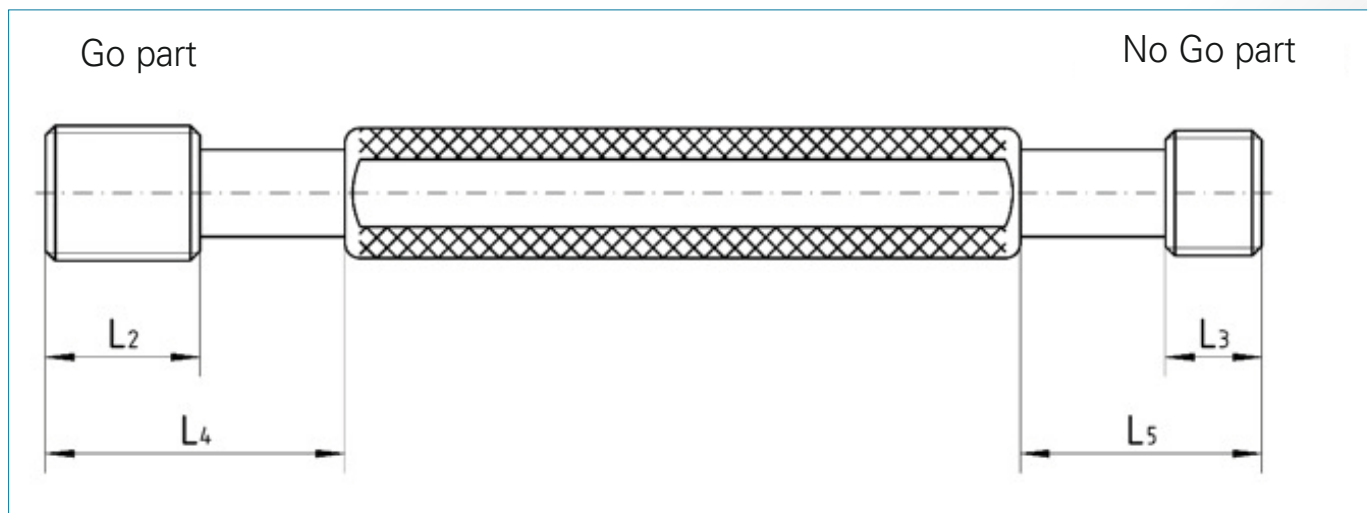



Special threads and other standardized threads

We can offer thread gauges for special threads on request.

Please send us all the necessary information on the applicable standards and specifications for the workpiece thread to.

This can, for example, be in the form of a graphic representation of the thread profile specifying the major, pitch and minor diameter including the tolerances.

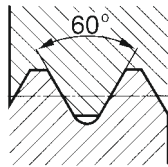
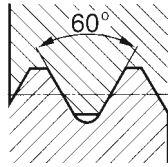
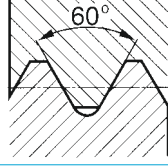
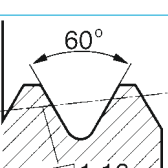
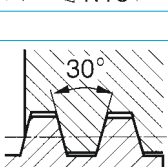
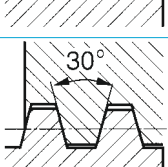
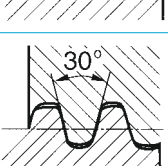
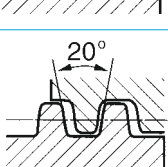
We also offer thread gauges for other standardized threads on request. This includes:

Description	Index letter	Designation (example)	Nominal size	Profile of thread	acc. to standard	Application
MJ-thread	MJ	MJ 6 x 1 - 4h6h	1,6 to 39 mm		DIN ISO 5855 Part 1 and 2	aerospace
		MJ 6 x 1 - 4H5H				
Metric thread with large clearance	M	DIN 2510 - M 36	12 to 180 mm		DIN 2510 Part 2	For bolted connections with waisted shank
ISO-metric screw thread helical coil thread for inserts	EG M	DIN 8140 - EG M 20	2 to 52 mm		DIN 8140 Part 2	Helical coil threads (coarse and fine threads) for wire thread inserts
ISO-metric screw thread for transition fits (former: thread for interference fit)	M	M10 - Sn 4 M10 - Sk 6	3 to 150 mm		DIN 13 Part 51	for screw ends on stud bolts
		M10 - Sn 4 dicht	3 to 150 mm			not sealing sealing
Metric external taper screw thread	M	DIN 158 M 30 x 2 keg	5 to 60 mm		DIN 158	for sealing screws and lubrication nipples
		DIN 158 M 30 x 2 keg kurz				
ISO-metric Trapezoidal screw thread (single- and multistart) Stub metric trapezoidal screw thread (single- and multistart)	Tr	Tr 40 x 7 Tr 40 x 14 P7	8 to 300 mm		DIN 103 Teil 1 to 8	general
		DIN 380 - Tr 48 x 8 DIN 380 - Tr 40 x 14 P7			DIN 380 Part 1 and 2	
Trapezoidal screw thread (single- and doublestart) with clearance	Tr	DIN 263 - Tr 48 x 12	48 mm		DIN 263	for rail vehicles
		DIN 263 - Tr 40 x 16 P8	40 mm		DIN 6341 Part 2	for draw-in collets
		DIN 6341 - Tr 32 x 1,5	12 to 32 mm			
Rounded trapezoidal thread	Tr	DIN 30 295 - Tr 40 x 5	26 to 80 mm		DIN 30 295 Part 1 and 2	for rail vehicles
Trapezoidal thread	KT	DIN 6063 - KT 22	10 to 50 mm		DIN 6063 Part 2	for plastic containers







Special threads and other standardized threads

We can offer thread gauges for special threads on request.

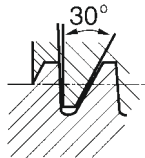
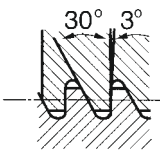
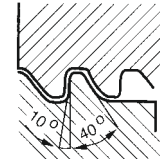
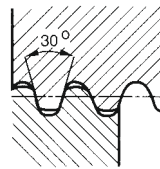
Please send us all the necessary information on the applicable standards and specifications for the workpiece thread to. This can, for example, be in the form of a graphic representation of the thread profile specifying the major, pitch and minor diameter including the tolerances.

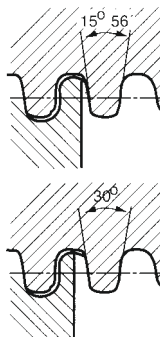
We also offer thread gauges for other standardized threads on request. This includes:

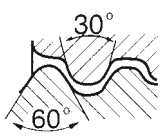
Description	Index letter	Designation (example)	Nominal size	Profile of thread	Acc. to standard	Application
Metric buttress screw thread (single- and multistart)	S	S 48 x 8	10 to 640 mm		DIN 513 Part 1 to 3	general
		S 40 x 14 P7				
Buttress screw thread	S	DIN 20 401 - S 25 x 1,5	6 to 40 mm		DIN 20 401	mining
	KS	DIN 6063 - KS 22	10 to 60 mm		DIN 6063 Part 1	for plastic containers
Round thread (single- and multistart)	Rd	Rd 40 x 1/6	8 to 200 mm		DIN 405 Part 1 and 2	general
		Rd 40 x 1/3 P 1/6				
Round thread		Rd 40 x 5	10 to 300 mm		DIN 20 400	with large load-bearing depth for the mining
		DIN 15 403 - Rd 80 x 10	50 to 320 mm		DIN 15 403	for lifting hooks
Round thread		DIN 7273 - Rd 70	20 to 100 mm		DIN 7273 Part 1	for steel sheet pieces and appropriated couplings
Round thread with clearance	Rd	DIN 262 - Rd 59 x 7	34 to 79 mm		DIN 262 Part 1 and 2	for rail vehicles
		DIN 262 - Rd 59 x 7 links				
		DIN 264 - Rd 50 x 7	50 mm		DIN 264 Part 1 and 2	
		DIN 264 - Rd 50 x 7 links				
Round thread	Rd	DIN 3182 - Rd 110 x 1/3	110 mm		DIN 3182 Part 1	for respiratory protection
		DIN EN 148-1 - Rd 40 x 1/7	40 mm		DIN EN 148 Part 1	
		GL	DIN 168 - GL 20 x 3	8 bis 125 mm		DIN 168 Part 1

Special threads and other standardized threads

We can offer thread gauges for special threads on request.

Please send us all the necessary information on the applicable standards and specifications for the workpiece thread to.

This can, for example, be in the form of a graphic representation of the thread profile specifying the major, pitch and minor diameter including the tolerances.

We also offer thread gauges for other standardized threads on request. This includes:

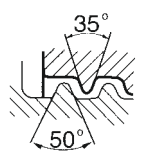
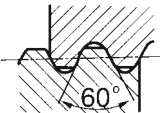
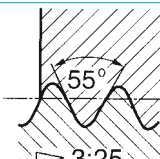
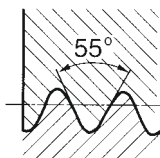
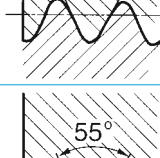
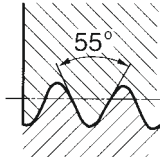
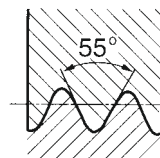
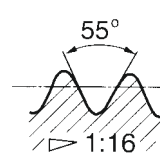
Description	Index letter	Designation (example)	Nominal size	Profile of thread	Acc. to standard	Application
Glass thread	Glasg	DIN 40 450 Glasg 74,5	74,5 mm 84,5 mm 99 mm 123,5 mm 158 mm 188 mm		DIN 40 450	cover glasses and caps in electrical engineering
Thread for valves	Vg	DIN 7756 - Vg 12	5 to 12 mm		DIN 7756	valves for tyres
Taper Whitworth thread	W	DIN 477 - W 31,3 x 1/14	19,8 mm *) 28,8 mm **) 31,3 mm		DIN 477	screw sockets for gas cylinder valves
Cylindrical Whitworth thread		DIN 477 W 21,8 x 1/14	21,8 mm 24,32 mm 25,4 mm		DIN 477	Valve outlets for gas cylinders
		W 80 x 1/11	80 mm		DIN EN ISO 11117	for protection caps of gas cylinders
RMS thread	RMS	DIN 58 888 - RMS ISO 8038 - RMS	20,32 mm		DIN 58 888 ISO 8038	for microscope objectives
Whitworth pipe thread, cylindrical internal thread	Rp	DIN 3858 - Rp 1/8	1/8 to 1 1/2		DIN 3858	internal thread for pipe fittings
Whitworth pipe thread, taper external thread	R	DIN 3858 - R 1/8-1	1/8 to 1 1/2		DIN 3858	external thread for pipe fittings

For left hand threads the internationally used abbreviation LH (= left Hand) is added to the designation of thread.

For parts that are available with either right or left hand thread, also for right hand threads the additional information RH (= Right Hand) added to the designation of thread.

*) replaced by 17E according to DIN EN ISO 11363-1 and -2

**) replaced by 25E according to DIN EN ISO 11363-1 and -2

Inspection set for metric coarse thread

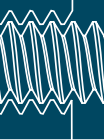

0

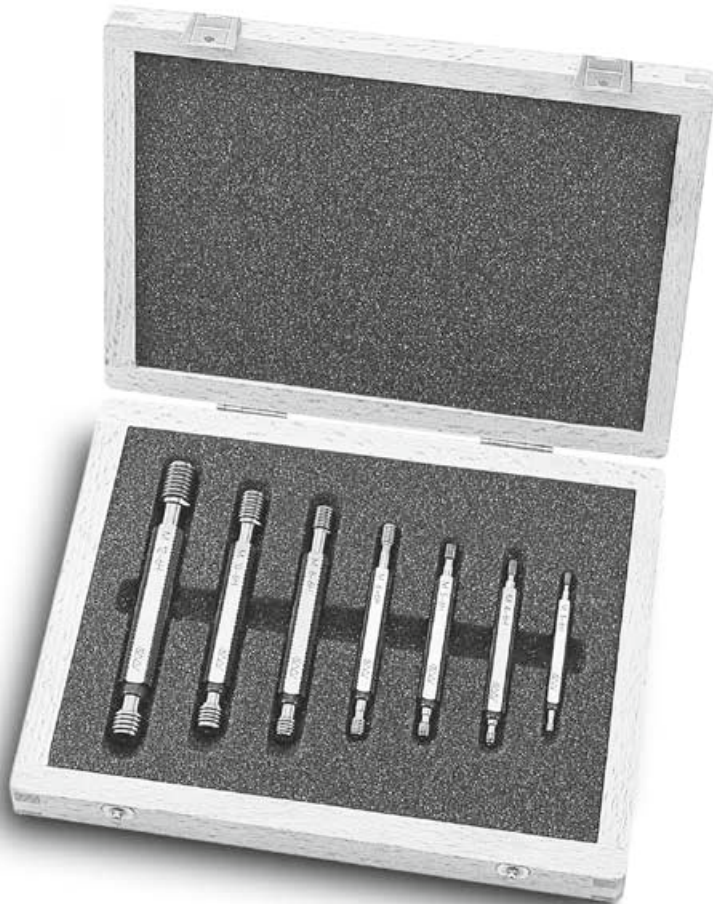

000S

Limit thread plug gauges in set

consisting of 1 piece each size

M3 · M4 · M5 · M6 · M8 · M10 · M12

Tolerance class 6H

including inspection
protocol for each gauge

Other set compositions also with thread ring gauges on request

protection box in wood

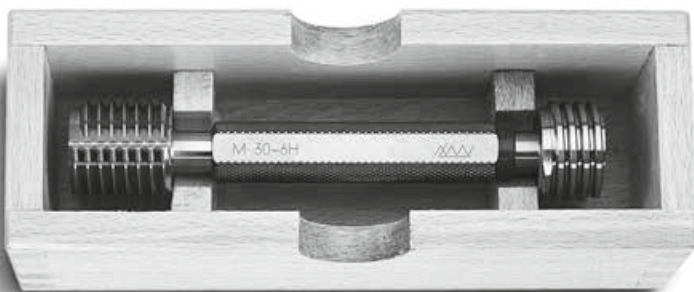

For limit plug gauges,
nominal diameter up to 65 mm
and for limit thread plug gauges up to 40 mm
protection boxes in wood,
natural-lacquered, can be supplied on request.





1

Gauges for cylindrical fits, taper- and gears

The manufacturing tolerances and the admissible wear

The manufacturing tolerances and the admissible wear for gauges of linear size are contained in DIN EN ISO 1938-1 and DIN EN ISO 1938-2.

For the inspection of new gauges it is to be considered, that the Go part includes a wear allowance (z for gauges for internal sizes and z1 for gauges for external sizes) according to DIN EN ISO 1938-1.

The limit deviations as described on the gauge are therefore not identical with the nominal size of the new Go part.

Frequently the wear allowance of the Go part does not become considered during the incoming goods inspection and leads to unjustified complaints.

Sample of gauge dimensions.

Gauge for internal sizes, limit plug gauge 30 H9

GO, new	lower limit of size of workpiece	30,000 mm
	wear allowance + z	0,009 mm
		30,009 mm
	manufacturing tolerance $\pm \frac{H_1}{2}$	0,002 mm
	upper limit of size of gauge	30,011 mm
	lower limit of size of gauge	30,007 mm
NO GO	upper limit of size of workpiece	30,052 mm
	manufacturing tolerance $\pm \frac{H_1}{2}$	0,002 mm
	upper limit of size of gauge	30,054 mm
	lower limit of size of gauge	30,050 mm

Gauge for external sizes, limit snap gauge 50 h6

GO, new	upper limit of size of workpiece	50,000 mm
	wear allowance - z ₁	0,0035 mm
		49,9965 mm
	manufacturing tolerance $\pm \frac{H_1}{2}$	0,002 mm
	upper limit of size of gauge	49,9985 mm
	lower limit of size of gauge	49,9945 mm
NO GO	lower limit of size of workpiece	49,984 mm
	manufacturing tolerance $\pm \frac{H_1}{2}$	0,002 mm
	upper limit of size of gauge	49,986 mm
	lower limit of size of gauge	49,982 mm

Limit plug gauges

1000

Limit plug gauges for Go and No Go inspection of bores

available nominal sizes

0,5 - 250 mm

above 250 mm make inquiry

Gauge dimensions acc.

DIN EN ISO 1938-1 and DIN 7164

Blanks dimensions acc.

DIN 2245/2246/2247/2248/2249

Go and No Go part hardened gauge steel

Handle mounting according to company standard:

Nominal diameter 0,5 – 70 mm on one handle

Nominal diameter above 70 mm split in 2 parts

Executions:

1001

Go hard chromed

No Go hardened steel

1002

Go and No Go hard chromed

1003

Go tungsten carbide

No Go hardened steel

available nominal sizes

1 - 50 mm

up to 1 mm and above 50 mm

on request

1004

Go and No Go tungsten carbide

available nominal sizes

1 - 50 mm

up to 1 mm and above 50 mm

on request

▼ Limit plug gauge up to 40 mm

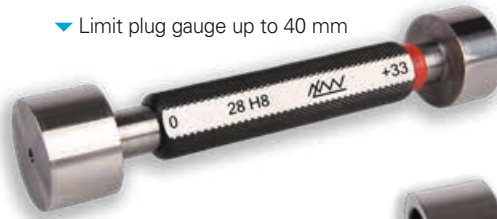

▼ Limit plug gauge above 40 mm



Execution above 70 mm, 2 parts
Go part



No Go part



▲ Limit plug gauge up to 70 mm single-part

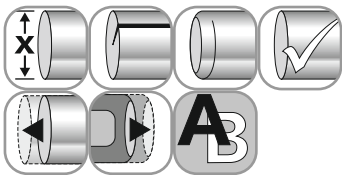

Reference disk gauges (checking gauges for gap gauges):

request for quotation required

Limit plug gauge with special characteristics

We are available to provide limit plug gauges with special specifications.

This includes the determination of the tolerance, the choice of material, a possible coating and the execution of dimensions for special purposes.

The relevant documents for limit plug gauges or limit thread plug gauges are on our website at MEDIA under Technology.

Or under the link:

Limit plug gauge

<https://www.lehrmess.de/images/media/Formular-Grenzlehrdorn.pdf>

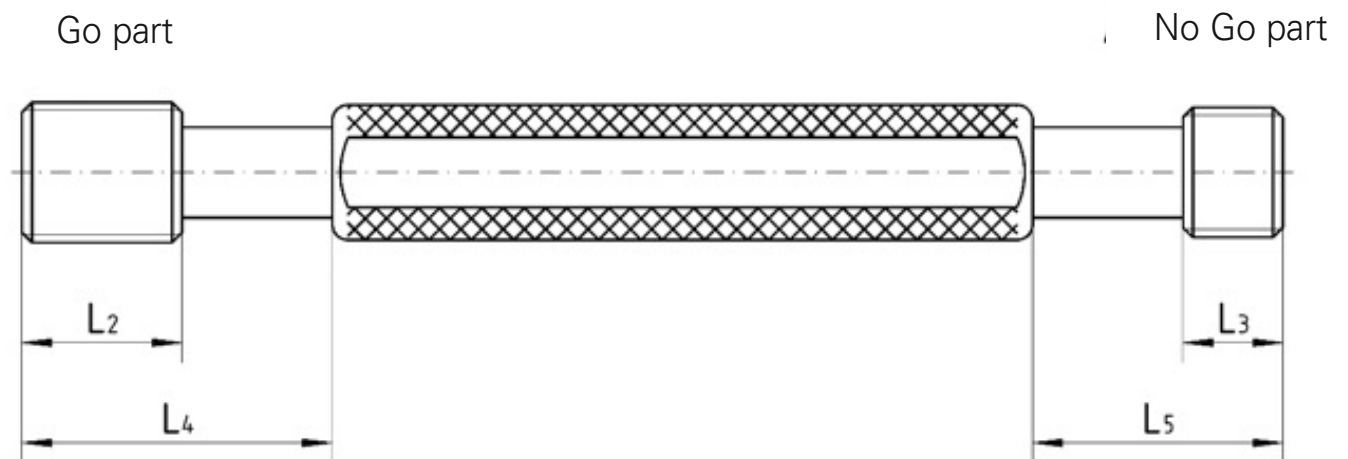

1

Flat limit plug gauge

1700

Flat limit plug gauge for Go and No Go inspection of bores

available nominal sizes
8 - 100 mm one part

Blanks dimension according to company
standard gauge dimensions
acc. DIN EN ISO 1938-1 and DIN 7164

Gauging surfaces hardened,
ground and lapped
forged blank

available executions:

1750

Flat Go plug gauge

1760

Flat No Go plug gauge

nominal sizes range
above 100 - 200 mm 2 parts
forged blank

nominal sizes range
above 200 - 360 mm 2 parts
gauge body of hardened gauge steel

above 360 mm on request



Square/Hexagon limit plug gauges

1

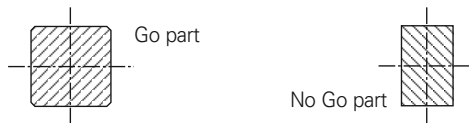

1020

Square limit plug gauges

Go and No Go part - hardened steel

nominal sizes range

2 - 70 mm – up to 2 mm on request

gauge dimensions acc.

DIN EN ISO 1938-1 and DIN 7164

hardened, aged

gauging surfaces super finished

No Go part with 2 gauging surfaces

On orders please indicate:

Nominal size and tolerance class or tolerance of workpiece

e.g. **SW 10 H7** or **SW 10+0,05**

execution: tungsten carbide, hard chromed or other coatings on request.

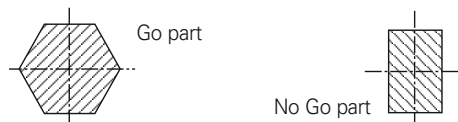

1030

Hexagon limit plug gauges

Go and No Go part - hardened steel

nominal sizes range

3 - 80 mm – up to 3 mm on request

gauge dimensions acc.

DIN EN ISO 1938-1 and DIN 7164

hardened, aged

gauging surfaces super finished

No Go part with 2 gauging surfaces

On orders please indicate:

Nominal size and tolerance class or tolerance of workpiece

e.g. **SW 10 H10** or **SW 10+0,1**

execution: tungsten carbide, hard chromed or other coatings on request.

Other profiles on request

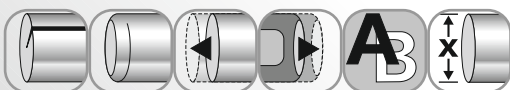

In addition to these standard dimensions, we also manufacture plug gauges in special lengths, No Go parts with square or hexagon and gauges according to customer drawing. Square and hexagon ring gauges on request.

Limit gap gauges double sided

gauge dimensions acc. DIN EN ISO 1938-1 and DIN 7163

1230

Limit gap gauges double sided composed

Go and No Go part hardened gauge steel
nominal sizes range
0,5 - 5 mm

gauging surfaces hardened,
ground and lapped.

Go and No Go part hard chromed
or tungsten carbide on request.



1210

Limit gap gauge double sided

Go and No Go part hardened gauge steel
nominal sizes range
3 - 100 mm

gauging surfaces hardened,
ground and lapped
blank forged

other Execution:

1211

Go part hard chromed
No Go part gauge steel

1212

Go and No Go part
hard chromed

1213

Go part tungsten carbide
No Go part gauge steel

1214

Go and No Go part
tungsten carbide





1260

Limit gap gauge single sided

forged Version

hardened gauge steel

nominal size range

3 - 214 mm



Blanks dimension acc. DIN 2231

gauging surfaces hardened,
ground and lapped

other Execution:

1262

Go and No Go part hard chromed

1263

Go and No Go part tungsten carbide



1200

Limit gap gauges

single sided

in steel plate

nominal size range

3 - 520 mm



Blanks sizes:

from 3 - 160 mm acc. DIN 2235

above 160 mm acc. company standard

gauging surfaces hardened,
ground and lapped

larger dimensions
available on request

Limit gap gauge for checking grooves in steel plate

1202

Limit gap gauge for groove diameter inspection in steel plate

Go and NoGo checking

Steel plate

nominal sizes range

3 - 100 mm

gauging surfaces offset for grooves, ground and lapped

Blanks sizes acc. DIN 2235

On order please indicate:

Nominal size and tolerance for the groove diameter and for the width of the groove.

e.g. 22 d9 x 0,8



1220

Limit gap gauges for groove diameters and groove width

Go and NoGo checking

Steel plate

nominal sizes range

3 - 100 mm

gauging surfaces offset for grooves, ground and lapped

Blanks sizes acc. DIN 2235

On order please indicate:

Nominal size and tolerance for the groove diameter and for the width of the groove.

e.g. 19,2 d9 x 2 +0,2

nominal size under 3 mm on request.



Setting ring gauge

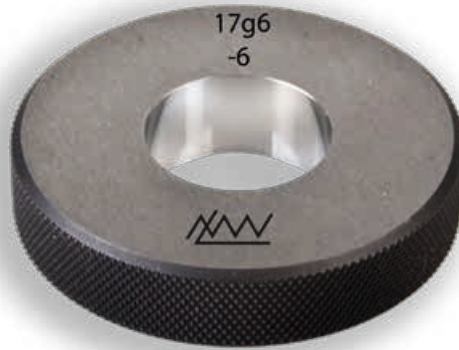

▲ Go ring gauge No. 1140

1140

Go ring gauge

gauge steel

nominal sizes range

1 - 500 mm

gauge dimensions acc.

DIN EN ISO 1938-1 and DIN 7163

Blanks sizes acc. DIN 2250

type C

gauging surfaces hardened,
ground and lapped

other Execution:

1150

Go ring gauge DIN 2250 type G

1141

No Go ring gauge DIN 2254



▲ No Go ring gauge
No. 1141

1130

Setting ring gauges for reamers

gauge steel

nominal sizes range

1 - 100 mm

Blanks sizes acc. DIN 2250 type R

gauging surfaces hardened,
ground and lapped

The nominal sizes of the bore of the
setting ring for reamers acc. to DIN 2250
results from the lower limit of size of the
workpiece bore plus $\frac{2}{3}$ of the tolerance
of workpiece bore.

1100

Setting ring gauges for measuring instruments

gauge steel

nominal sizes range

1 - 500 mm

Blanks sizes acc. DIN 2250

type C

gauging surfaces hardened,
ground and lapped

other Execution:

1110

setting rings for pneumatic length
measuring instruments acc. DIN 2250
type B



◀ setting ring gauge for measuring
instruments up to 100 mm

setting ring gauge for measuring instruments
No. 1100 ▶

The marking is carried out with the actual
size down to 3 decimal places, over
Ø 100 with the actual deviation.

Setting rings above 100 mm are available
in wooden box. The delivery in sets
is in one storage box possible



Keyseating gauges for shafts

1410

Keyseating gauges for shafts

standard

shaft-Ø-range

10 - 330 mm

for standardized groove width

acc. DIN 6885/6886/6887

Sliding parts for other groove widths and tolerances are as specified the desired dimensions in special manufacturing.

Keyseating gauges for shafts are used for checking width, depth and symmetry of keyseats for shafts.

The easily replaceable sliding part enables these characteristics to be checked in every possible diameter range.

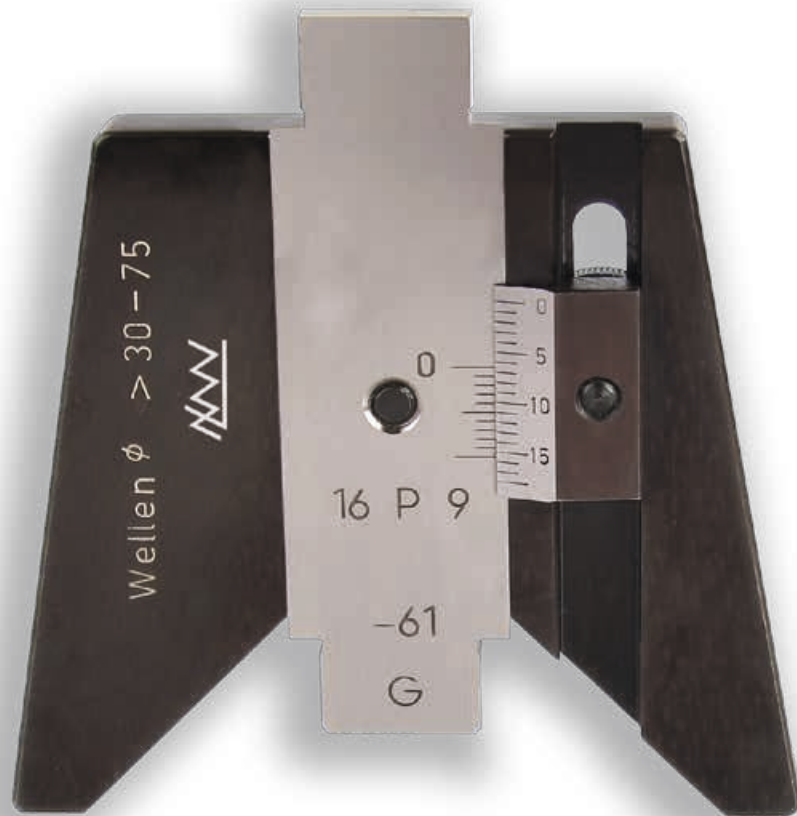

1430

Exchangeable sliding parts

tolerance classes

P9, N9, P8, N8 or D10

Inspection of keyseats of shafts with the keyseating gauge

1. Setting of the keyseating gauge:

The gauge is set onto the full fraction of the shaft. The sliding part is moved down to the shaft and clamped. In that position the zero graduation of the depth measuring scale is brought in coincidence with the zero mark of the vernier. Afterwards the measuring scale is clamped and the screw of the sliding part is loosened.

2. Inspection with the keyseating gauge:

The gauge is set onto the shaft and the sliding part is moved until reaching the ground of the slot. The depth of the slot can be read from the mm graduation of the depth scale. By that also the width of the slot has been checked for GO and for the "concentricity". The NO GO inspection of the slot width is carried out by the opposite side of the sliding part.



1



2

Size no.	shaft diameter	Groove widths in mm for interchangeable sliding parts
1	10 - 30 mm	3 4 5 6 8
2	above 30 - 75 mm	10 12 14 16 18 20
3	above 75 - 150 mm	22 25 28 32 36
4	above 150 - 230 mm	40 45 50
5	above 230 - 330 mm	56 63 70

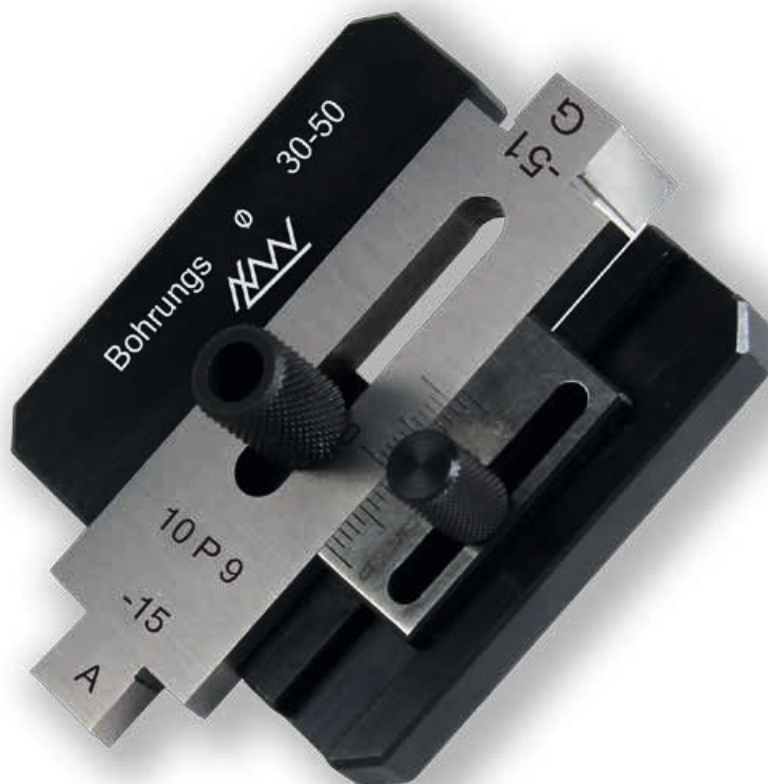

1420

Keyseating gauges for hubs standard version

hub Ø range
10 - 330 mm

for standardized slot widths acc. to DIN 6885/6886/6887

Sliding parts for other groove widths and tolerances are as specified the desired dimensions in special manufacturing.

Keyseating gauges for hubs are used for checking of width, depth and symmetry of the groove in hubs.

The easily replaceable sliding parts enables these characteristics to be checked in every possible diameter range.

1440

Sliding part

tolerance classes
P9, JS9, P8, JS8 or D10

Inspection of keyseats of hubs with the keyseating gauge

1. Setting of the keyseating gauge:

The gauge is set onto the front end of the workpiece. During this the end stop pins are touching to the left and to the right of the slot in the bore. Afterwards the slider is moved to the board of the bore, clamped and the zero mark of the depth scale is brought in coincidence with the zero mark of the vernier on the sliding part. The measuring scale is clamped and the screw of the sliding part is loosened.

2. Inspection with the keyseating gauge:

The gauge is set onto the front end of the workpiece (end stop pins opposite the slot) and the sliding part is moved to the ground of the slot. The depth of the slot can be read now on the depth scale. By that also the width of the slot has been checked for GO and for the "concentricity".

The inspection for NO GO of the width of the slot is carried out by the opposite side of the sliding part.

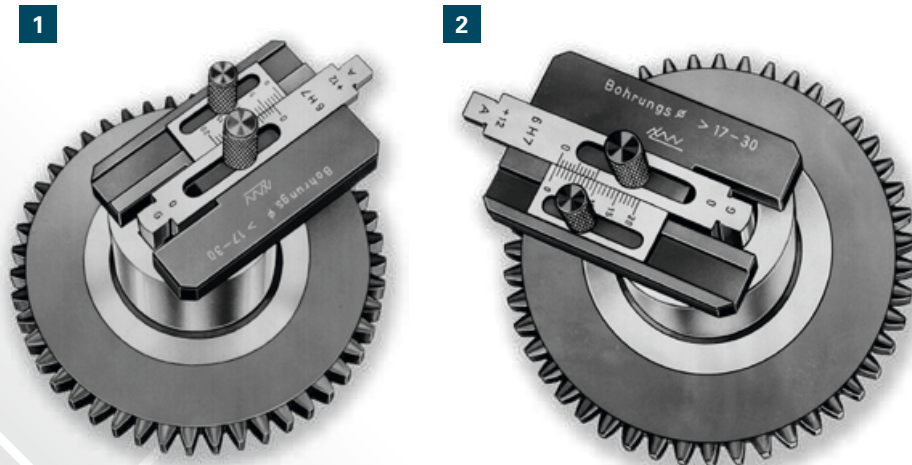

Size no.	bore diameter	Groove widths in mm for interchangeable sliding parts
1	10 - 17 mm	3 4 5
2	above 17 - 30 mm	6 8
3	above 30 - 50 mm	10 12 14
4	above 50 - 75 mm	16 18 20
5	above 75 - 110 mm	22 25 28
6	above 110 - 150 mm	32 36
7	above 150 - 230 mm	40 45 50
8	above 230 - 290 mm	56 63
9	above 290 - 330 mm	70

Limit keyset gauges (block gauges)

1400

Limit keyset gauges

Go and No Go part in wear resistant gauge steel

nominal sizes range

1 - 100 mm

above 100 mm on request

hardened and aged,
gauging surfaces super finished



Limit keyset gauges serve for inspection of flat fits particularly of slots in shafts and hubs.

On order please indicate:

Nominal size and tolerance class or the tolerance of the workpiece.

e.g. 8P9 or 8+0,04

other Execution:

1401

Go and No Go part hard chromed

TiN/TiCN on request

tungsten carbide on request

construction dimensions

acc. works standard

range of nominal sizes mm	L1	L2	L3	b
1 to 6	14	11	60	10
above 6 to 10	14	11	60	10
above 10 to 18	17	13	70	10
above 18 to 30	20	16	80	12
above 30 to 50	22	18	100	12
above 50 to 60	30	20	100	10
above 60 to 80	35	20	120	10
above 80 to 100	40	25	140	10

changes reserved

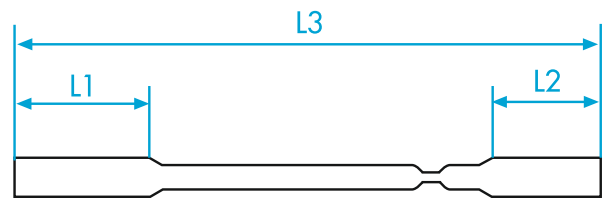
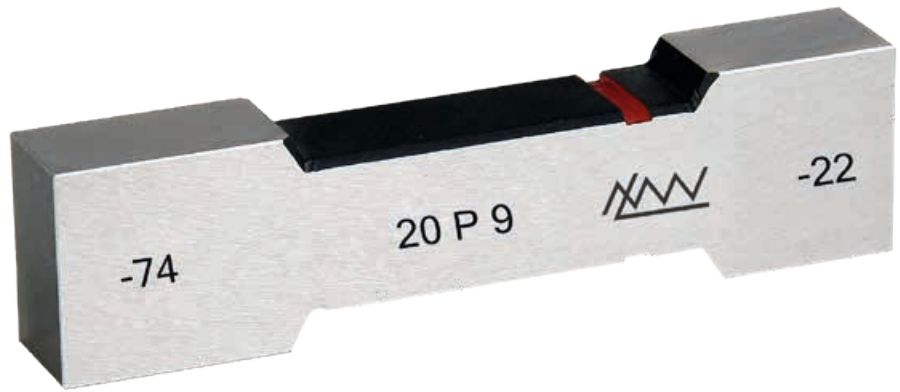

outfit up to nominal size 6 mm

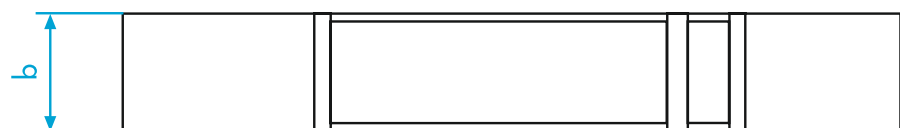
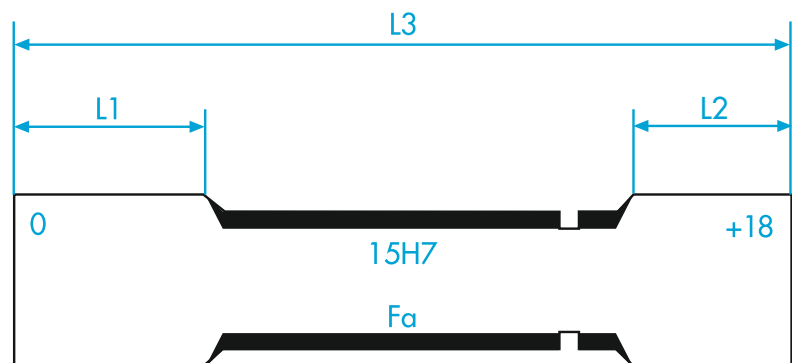

outfit above 6 to 150 mm



2000

Precision measuring cylinders in wear - resistant steel

superfinished and lapped

Suitable for inspection of right angles and
for acceptance tests of machines.

Ø x length mm	approx. mass kg	accuracy ± µm
90 x 200	6,5	2,0
90 x 250	7,8	2,2
90 x 300	9,1	2,5
90 x 350	10,4	2,8
90 x 400	11,5	3,0

other execution on request

Taper gauges

1300

Morse taper plug gauge without tang

Nominal No.

0, 1, 2, 3, 4, 5, 6 DIN 229



other Execution:



▲ Morse taper plug gauge without tang
No. 1300

1310

Morse taper plug gauge with tang

DIN 230

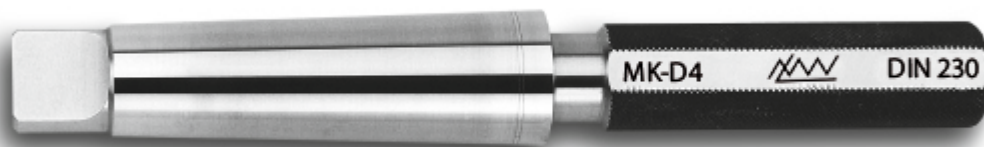

▲ Morse taper plug gauge with tang
No. 1310

1301

Morse taper sleeve gauge without tang

Nominal No.

0, 1, 2, 3, 4, 5, 6 DIN 229



other Execution:



▲ Morse taper sleeve gauge without tang
No. 1301

1311

Morse taper sleeve gauge with single-sided tang

DIN 230

Morse taper gauges are used for testing tapered shanks and bores for tools and machine tools.



▲ Morse taper sleeve gauge with
single-sided tang
No. 1311

Taper gauges



▲ Taper plug gauge without tang
No. 1320

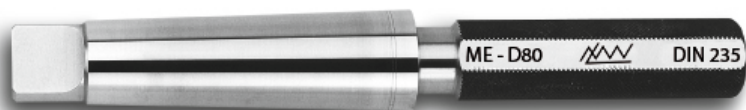

▲ Taper plug gauge with tang
No. 1330



▲ Taper sleeve gauge with tang
No. 1331



▲ 7/24 taper sleeve gauge
No. 1341

▼ 7/24 taper plug gauge
No. 1340



1320

Metric taper plug gauge without tang

Nominal No.
4, 6, 80, 100, 120 DIN 234



other Execution:

1330

Metric taper plug gauge with tang

80, 100, 120 DIN 235

1321

Metric taper sleeve gauge without tang

Nominal No.
4, 6, 80, 100, 120 DIN 234



other Execution:

1331

Metric taper sleeve gauge with tang

80, 100, 120 DIN 235

1340

7/24 taper plug gauge

Nominal No.
30, 40, 45, 50, 55, 60, 65 DIN 2079



1341

7/24 taper sleeve gauge DIN 2080



other Execution, available on request:

- 1/4 taper acc. ISO 702
- taper for spot welding devices according to DIN EN ISO 25822 or ISO 5822

- taper gauges for medical devices ISO594, ISO5356, ISO80369
- special taper gauges acc. workpiece drawing



▲ Test bars with morse taper No. 2100

2100

Test bars with morse taper

Without tightening thread but with external thread and forcing-off nut and with 4 index lines on the front end and on the rear fraction of the cylinder each. The marks on the front end are numbered from 1 to 4.

manufacturing tolerances:

cylindricity: $\leq 3 \mu\text{m}$
 run-out deviation: $\leq 3 \mu\text{m}$
 deviation from straightness: $\leq 3 \mu\text{m}$

taper	d mm	L mm
Morse 0	12	75
Morse 1	12	75
Morse 2	24	150
Morse 3	32	200
Morse 4	40	300
Morse 5	40	300
Morse 6	63	500

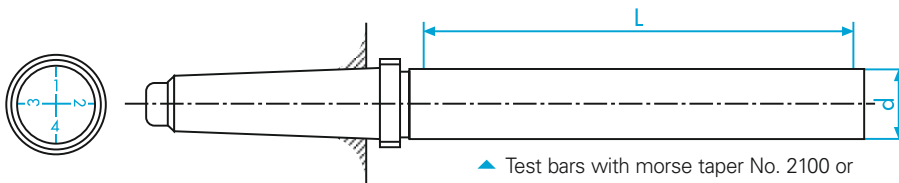

▲ Test bars with morse taper No. 2100 or Test bars with metric taper No. 2101

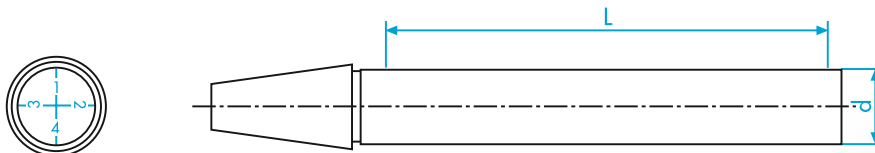

▲ Test bars with 7/24 taper No. 2102

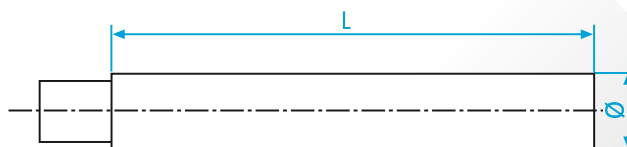

▲ Test bars for inspections between centres No. 2103

2101

Test bars with metric taper

Execution like No. 2100

taper	d mm	L mm
metric 80	80	500

2102

Test bars with 7/24 taper

Execution like No. 2100

however with tightening thread, but without external thread

taper	d mm	L mm
SK 20	24	150
SK 30	32	200
SK 30	32	300
SK 40	40	300
SK 45	40	300
SK 50	40	300
SK 50	63	500

delivery complete in a storage case on request.

2103

Test bars for inspections between centres

These test bars are required for run-out tests between centres on machine tools ecc. The length of the clamping area is 15 mm.

manufacturing tolerances:

cylindricity: $\leq 2 \mu\text{m}$
 run-out deviation: $\leq 2 \mu\text{m}$

\emptyset	x	useful length
12		150
16		150
20		250
30		250
40		400
50		400
40		500
50		500
60		500

delivery complete in a storage case on request.

Cylindrical measuring pins

Single measuring pins accuracy 1 in gradation 1/100 mm		
1500...0.2...1	measuring pin 0.10-0.20mm ±1.0μ	L=40mm, Gradition 0,01mm
1500...0.3...1	measuring pin 0.21-0.30mm ±1.0μ	L=40mm, Gradition 0,01mm
1500...0.5...1	measuring pin 0.31-0.50mm ±1.0μ	L=40mm, Gradition 0,01mm
1500...0.99..1	measuring pin 0.51-0.99mm ±1.0μ	L=40mm, Gradition 0,01mm
1500...2.....1	measuring pin 1.00-2.00mm ±1.0μ	L=70mm, Gradition 0,01mm
1500...3.....1	measuring pin 2.01-3.00mm ±1.0μ	L=70mm, Gradition 0,01mm
1500...6.....1	measuring pin 3.01-6.00mm ±1.0μ	L=70mm, Gradition 0,01mm
1500..10.2...1	measuring pin 6.01-10.20mm ±1.0μ	L=70mm, Gradition 0,01mm
1500..11.99..1	measuring pin 10.21-11.99mm ±1.0μ	L=70mm, Gradition 0,01mm
1500..13.99..1	measuring pin 12.00-13.99mm ±1.0μ	L=70mm, Gradition 0,01mm
1500..15.99..1	measuring pin 14.00-15.99mm ±1.0μ	L=70mm, Gradition 0,01mm
1500..18.99..1	measuring pin 16.00-18.99mm ±1.0μ	L=70mm, Gradition 0,01mm
1500..20.....1	measuring pin 19.00-20.00mm ±1.0μ	L=70mm, Gradition 0,01mm
1500..21.99..1	measuring pin 20.01-21.99mm ±1.0μ	L=70mm, Gradition 0,01mm
1500..23.99..1	measuring pin 22.00-23.99mm ±1.0μ	L=70mm, Gradition 0,01mm
1500..24.99..1	measuring pin 24.00-24.99mm ±1.0μ	L=70mm, Gradition 0,01mm

1510 / 1520 / 1530

Cylindrical measuring pins

for diameter range from
0,1 bis 20 mm

carefully hardened, aged, ground and lapped

From diameter 3 mm onwards the marking is on the front end.

The delivery is carried out separately or in boxes sets.

diameter mm	length mm	Accuracy
0,1- 3	30	± 0,5 μm
< 3 - 5	35	± 0,5 μm
< 5 - 10	40	± 0,5 μm
< 10 - 20	70	± 1 μm

Measuring pin sets in storage container:

diameter mm	number of measuring pins in steps of		
	0,1 No. 1510	0,05 No. 1520	0,01 No. 1530
0,1- 0,3	-	-	21
0,3- 0,5	-	-	21
0,5- 1	-	-	51
0,1- 1	-	19	-
1 - 2	11	21	101
2 - 3	11	21	101
3 - 4	11	21	101
4 - 5	11	21	101
5 - 6	11	21	101
6 - 7	11	21	101
7 - 8	11	21	101
8 - 9	11	21	101
9 - 10	11	21	101
< 10 - 11	11	21	100
< 11 - 12	11	21	100
< 12 - 13	11	21	100
< 13 - 14	11	21	100
< 15 - 16	11	21	100
< 16 - 17	11	21	100
< 17 - 18	11	21	100
< 18 - 19	11	21	100
< 19 - 20	11	21	100

other set composition on request



Single measuring pins accuracy 0 in gradation 1/1000 mm		
1500...0.2	measuring pin 0.100-0.200mm ±0,5μ	L=30mm, Gradition 0,001mm
1500...0.3	measuring pin 0.201-0.300mm ±0,5μ	L=30mm, Gradition 0,001mm
1500...0.5	measuring pin 0.301-0.500mm ±0,5μ	L=30mm, Gradition 0,001mm
1500...0.999.	measuring pin 0.501-0.999mm ±0,5μ	L=30mm, Gradition 0,001mm
1500...3.....	measuring pin 1.000-3.000mm ±0,5μ	L=70mm, Gradition 0,001mm
1500...5.....	measuring pin 3.001-5.000mm ±0,5μ	L=70mm, Gradition 0,001mm
1500..10.....	measuring pin 5.001-10.000mm ±0,5μ	L=70mm, Gradition 0,001mm

Single measuring pins accuracy 0 in gradation 1/1000 mm		
1500...0.2...0.5	measuring pin 0.10-0.20mm ±0,5μ	L=30mm, Gradition 0,01mm
1500...0.3...0.5	measuring pin 0.21-0.30mm ±0,5μ	L=30mm, Gradition 0,01mm
1500...0.5...0.5	measuring pin 0.31-0.50mm ±0,5μ	L=30mm, Gradition 0,01mm
1500...0.99..0.5	measuring pin 0.51-0.99mm ±0,5μ	L=30mm, Gradition 0,01mm
1500...3.....0.5	measuring pin 1.00-3.00mm ±0,5μ	L=30mm, Gradition 0,01mm
1500...5.....0.5	measuring pin 3.01-5.00mm ±0,5μ	L=35mm, Gradition 0,01mm
1500..10.....0.5	measuring pin 5.01-10.00mm ±0,5μ	L=40mm, Gradition 0,01mm

1600

Limit plug gauge for serration

Nominal diameter
7 x 8 - 120 x 125 mm
DIN 5481

hardened, ground



Serrations offer the following advantages: the larger number of teeth in mesh, the advantage that the shaft and hub and hub or shaft in the circumferential direction at smaller distances from tooth to tooth can be adjusted.

Serration with notch flanks:

e.g. DIN 5481; RVZ

Serration with involute flanks:

e.g. DIN 5480; DIN 5482; ANSI B82.1; BS 3550

Serration with wedge edges:

e.g. DIN ISO 14; DIN 5463; ISO 500; DIN 9611

Drive profiles:

e.g. Multi-tooth DIN 34824 or 6-Lobe ISO 10664



▲ Go and No Go plug for involute flanks serration

1601

Go plug gauge for serration and drives

1602

No Go plug gauge for serration and drives

1603

Go ring gauge for serration and drives

1604

No Go ring gauge for serration and drives

Special dimensions on request.



▲ Go and No Go ring for notch flanks serration





2

Special gauges

Gauges for medical appliances

Gauges for application in medical field

Reference connectors with external or internal taper acc. :

- DIN EN ISO 80369-3 (ISO 80369-3): Small-bore connectors for liquids and gases used in healthcare applications – Part 3: Connectors for enteral applications
- DIN EN ISO 80369-6 (ISO 80369-6): Small-bore connectors for liquids and gases in healthcare applications – Part 6: Connectors for neuraxial applications
- DIN EN ISO 80369-7 (ISO 80369-7): Small-bore connectors for liquids and gases in healthcare applications – Part 7: Connectors for intravascular or hypodermic applications

Taper plug gauges and taper ring gauges acc. :

- DIN EN ISO 5356-1 (ISO 5356-1): Anaesthetic and respiratory equipment - Conical connectors – Part 1: Cones and sockets
- DIN EN ISO 80601-2-74 (ISO 80601-2-74): Medical electrical equipment – Part 2-74: Particular requirements for basic safety, and essential performance of respiratory humidifying equipment
- DIN EN ISO 8637-2 (ISO 8637-2): Extracorporeal systems for blood purification – Part 2: Extracorporeal blood and fluid circuits for haemodialysers, haemodiafilters, haemofilters and haemoconcentrators

if requested by the customer, taper gauges in accordance with the following withdrawn or superseded standards:

- DIN EN 20594-1 (ISO 594-1): Conical fittings with a 6 % (Luer) taper for syringes, needles and certain other medical equipment – Part 1: General requirements
- DIN EN ISO 8638 (ISO 8638): Cardiovascular implants and extracorporeal systems – Extracorporeal blood circuit for haemodialysers, haemodiafilters and haemofilters

Gauges for standardized threads and gauges for special threads

Special gauges according to customer requirements and workpiece drawing

Please let us know your special requirements!



Customer requirements according to specifications

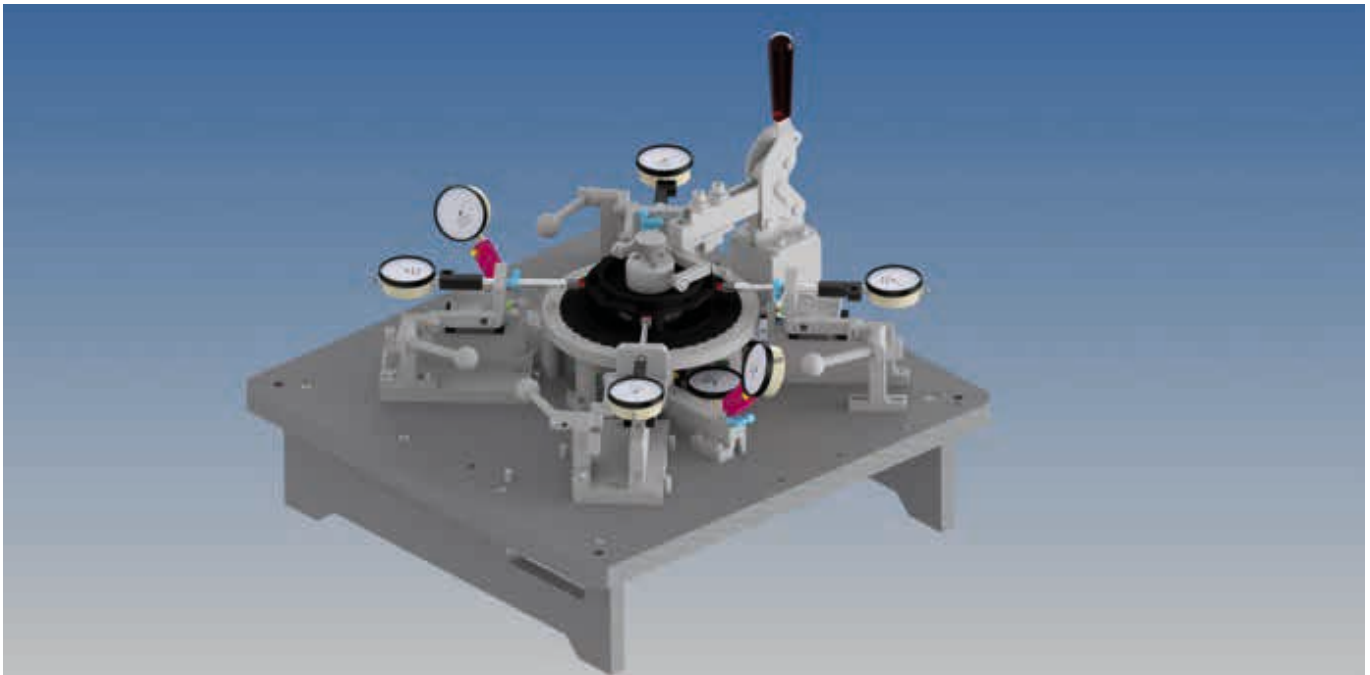
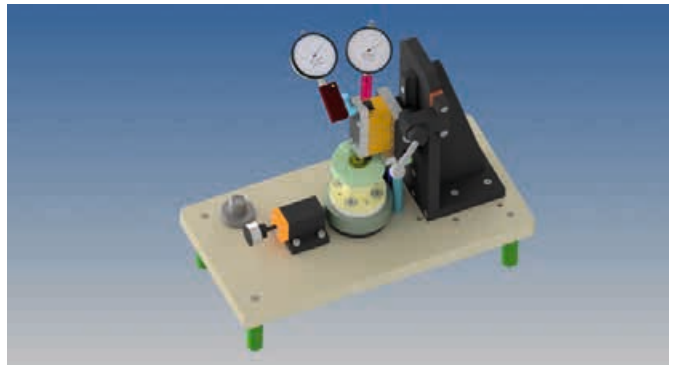
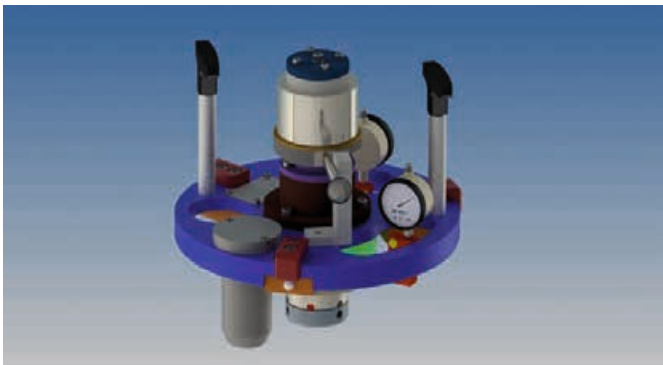
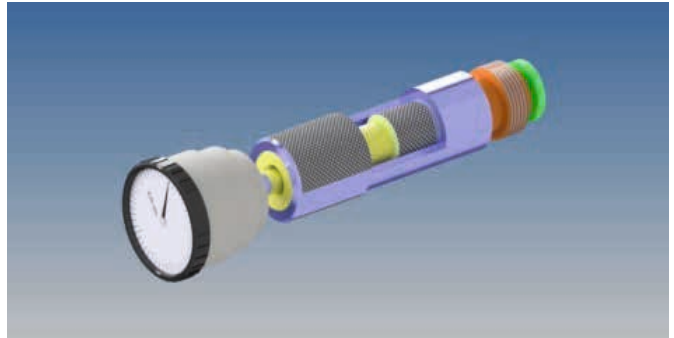
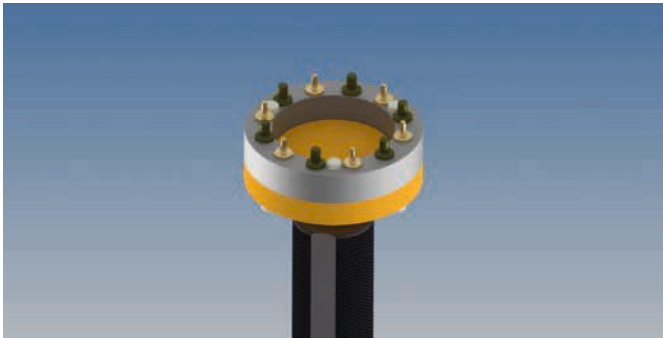
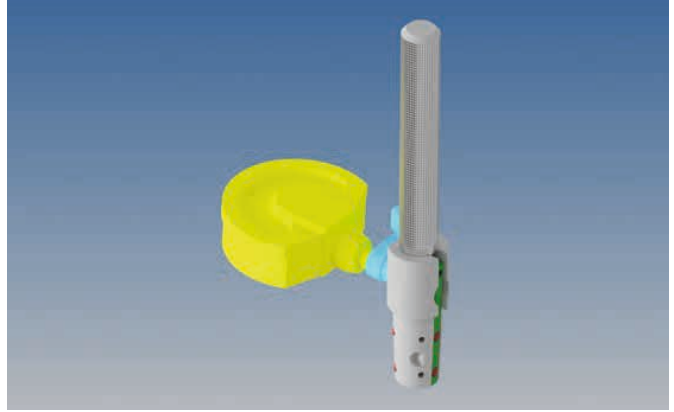
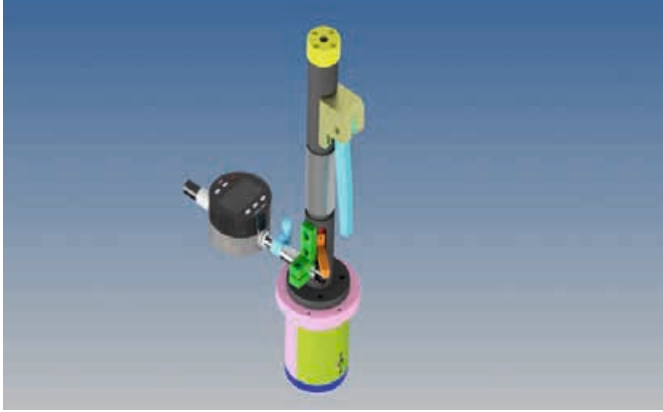



3

Kontroll-Service

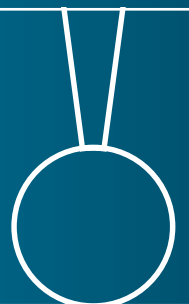

Inspection service for gauges



Permanently growing demands towards the quality assurance by legal regulations and rules, like ISO 9000 - 9004, lead to increasing efforts in the inspection and measuring field.

On the base of legal rules in force the manufacturers are forced to furnish an exact proof of the taken measures for the quality assurance.

The supervision of measuring and inspection equipment used in the production is hereby of striking importance. The installation of supervising systems particularly for the control of quickly wearing inspection equipment, like e.g. gauges, is going to represent a not unimportant cost factor in the future.



To support our customers at the supervision of their measuring and inspection equipment we have installed a gauge inspection service.

The measuring instruments used for the measurements are compared regularly with EAT-calibrated standards and therefore they meet highest quality requirements.



The traceability of the measure to national standards is turned into practice via a DKD-calibrated gauge block set and a set of setting ring gauges.

As inspection instructions for the supervision of gauges serve the VDI / VDE / DGQ-guide lines 2618.



3

Inspection service for gauges

Our inspection service includes the control of the following gauge types:

- Limit plug gauges
- Taper gauges
- Gap gauges
- Go and No Go ring gauges
- Setting ring gauges
- Setting masters
- Special gauges
- Thread gauges

We offer the following versions:

Manufacturing inspection protocol for new gauges

Inspection of delivered gauges with issuance of a supervision inspection protocol

Our calibration laboratory is accredited by the German Accreditation Body according to DIN EN ISO/IEC 17025:2018

The inspection routine includes:

- Cleaning of the gauges to be inspected
- Check on external damages
- Control of the main functional dimensions of the gauge
- Issue of the inspection protocol

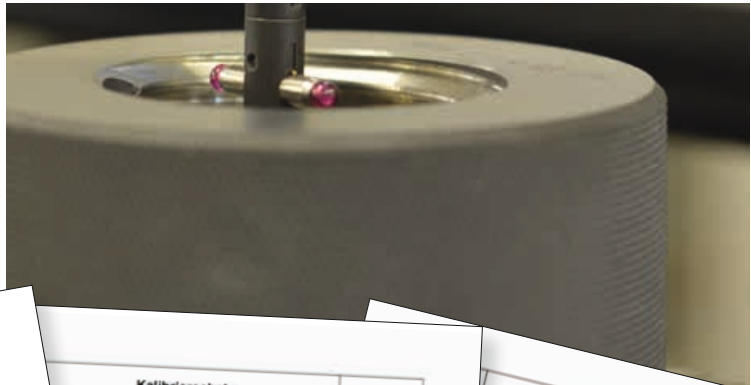
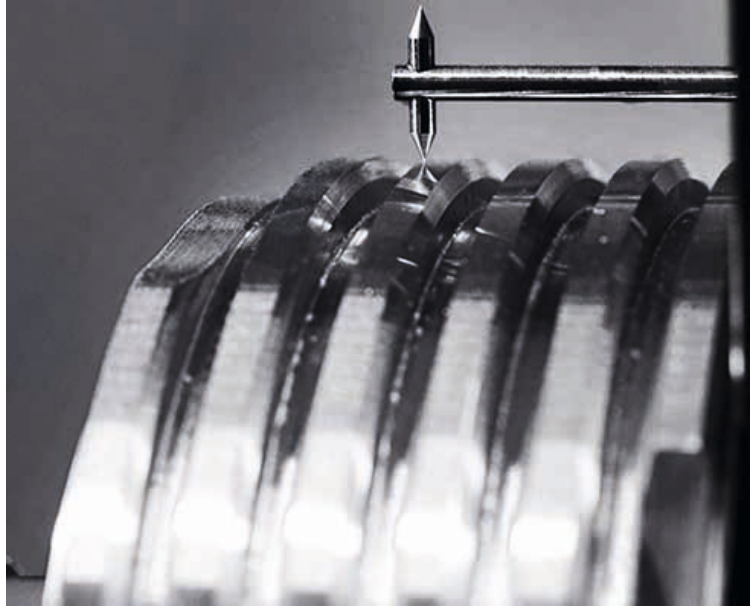

LMW Kalibrierservice
Wilhelm-Külz-Str. 49
98574 Schmalkalden

Order number: ABCDEF
Customer reference: UVWXYZ
Number of pages: 3
Date of calibration: 25.04.2022

Datum der Ausstellung: 25.04.2022
Freigabe des Kalibrierscheins durch: T. Grau
Stellv. Leiter Kalibrierlabor

DAKKS
Deutscher Akkreditationsrat
D 4-22043-01-00

Kalibrierzeichen
Calibration mark
000017
D-K-21443-01-00
2022-04

Kalibrierschein

Lehren- und Meißergerätekwerk Schmalkalden GmbH
Wilhelm-Külz-Str. 49
Tel.: 03683-668-0
Fax: 03683-668-100

98574 Schmalkalden
Tel.: 03683-6680
Fax: 03683-668100

M Zedl 4-4H
Metrische ISO Grunde nach DIN ISO 965-1 2017 / DIN ISO 1802 1996
30.00°/96.00° ± 31'
Ø 4000 mm ± 5.0 µm
1
Ø 2300 mm
Ø 2300 mm / Dreh-Ø Ausschussteile Ø 2300 mm
10.00 N
Metz-Angemessene nach Luftdrucktag 45% typ.

Größe	Ausschusswert	45% typ.
2.000 mm	1.880 µm	
1.990 mm	1.875 µm	
1.745 mm	1.700 µm	
1.744 mm	1.700 µm	
1.725 mm	1.700 µm	
1.500 mm	1.500 µm	

Kalibrierschein

Lehren- und Meißergerätekwerk Schmalkalden GmbH
Wilhelm-Külz-Str. 49
Tel.: 03683-6680
Fax: 03683-668100

98574 Schmalkalden
Tel.: 03683-6680
Fax: 03683-668100

Lehren - und Meißergerätekwerk Schmalkalden GmbH
Wilhelm-Külz-Str. 49
Tel.: 03683-6680
Fax: 03683-668100

98574 Schmalkalden
Tel.: 03683-6680
Fax: 03683-668100

Messunsicherheiten:
Zahnstöße: U=1, Sum
Durchmesser: U=1 µm
Flankenrichtungsfehler: U=1,2 µm
Summenrichtungsfehler: U=1,5 µm

Zertifikat PTB-50579 PTB16
Zertifikat C1192130A0
Zertifikat C116178370





Deutsche Akkreditierungsstelle GmbH

Beliehene gemäß § 8 Absatz 1 AkkStelleG i.V.m. § 1 Absatz 1 AkkStelleGBV
Unterzeichnerin der Multilateralen Abkommen
von EA, ILAC und IAF zur gegenseitigen Anerkennung

Akkreditierung



Die Deutsche Akkreditierungsstelle GmbH bestätigt hiermit, dass die

Lehren- und Meßgerätewerk Schmalkalden GmbH

Mit ihrem Kalibrierlaboratorium

LMW-Kalibrierservice

Wilhelm-Külz-Straße 49, 98574 Schmalkalden

die Kompetenz nach DIN EN ISO/IEC 17025:2018 besitzt, Kalibrierungen in folgenden Bereichen durchzuführen:

Dimensionelle Messgrößen

Länge

- Durchmesser
- Gewinde

Die Akkreditierungsurkunde gilt nur in Verbindung mit dem Bescheid vom 17.03.2022 mit der Akkreditierungsnummer D-K-21443-01. Sie besteht aus diesem Deckblatt, der Rückseite des Deckblatts und der folgenden Anlage mit insgesamt 2 Seiten.

Registrierungsnummer der Urkunde: **D-K-21443-01-00**

Berlin, 21.03.2022

Im Auftrag Dr. Florian Witt
Fachbereichsleiter

Die Urkunde samt Urkundenanlage gibt den Stand zum Zeitpunkt des Ausstellungsdatums wieder. Der jeweils aktuelle Stand des Geltungsbereiches der Akkreditierung ist der Datenbank akkreditierter Stellen der Deutschen Akkreditierungsstelle GmbH (DAkkS) zu entnehmen. <https://www.dakks.de/en/accredited-bodies-search.html>

Siehe Hinweise auf der Rückseite

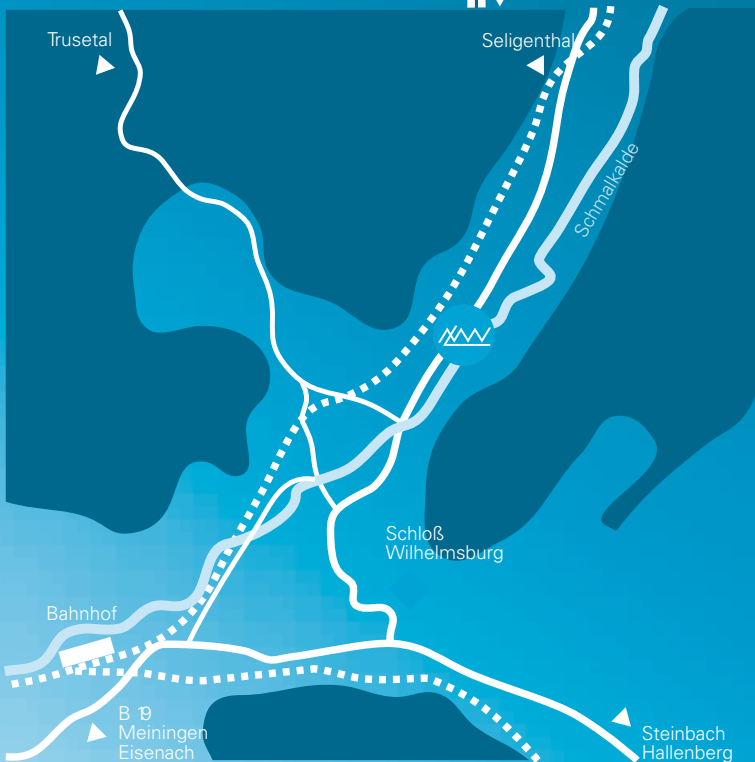
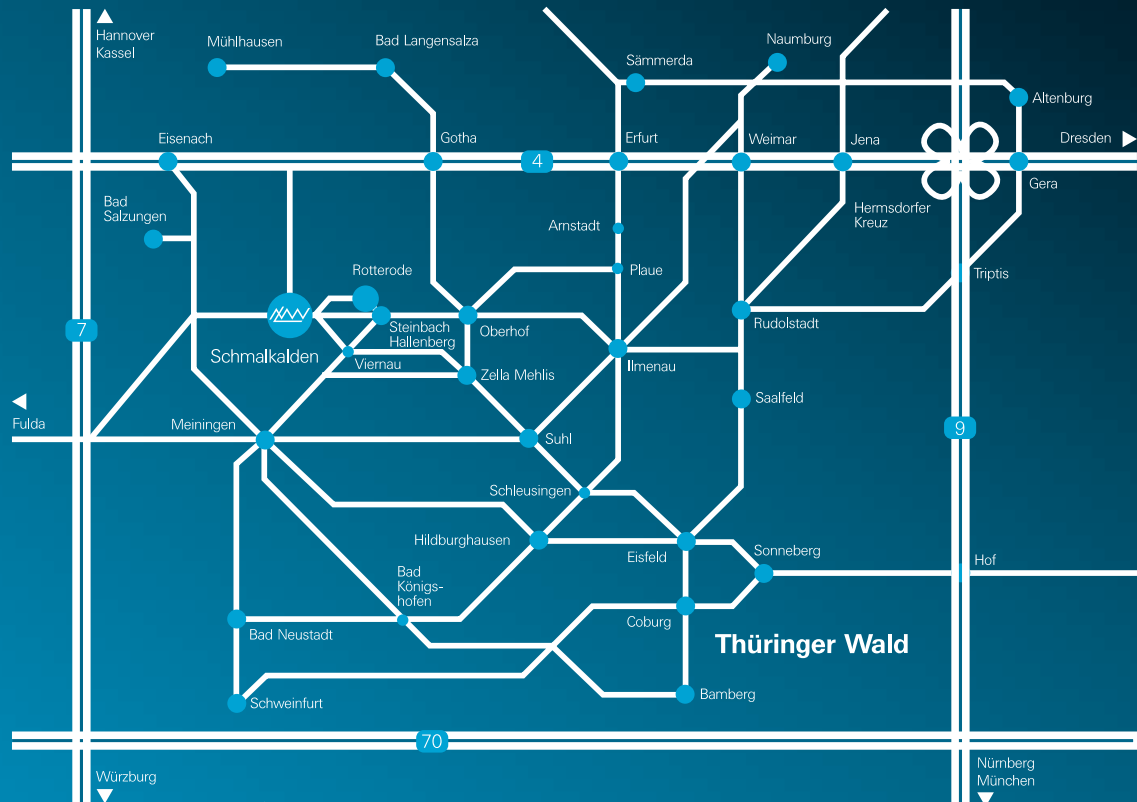

Lehr- und Meßgerätewerk Schmalkalden GmbH

Wilhelm-Külz-Straße 49
98574 Schmalkalden

Telefon +49 -(0) 36 83 -6 68 -0
Telefax +49 -(0) 36 83 -6 68 -100

www.lehrmess.de
info@lehrmess.de